

GEARED TRAVEL TROLLEY MODEL : GCL619

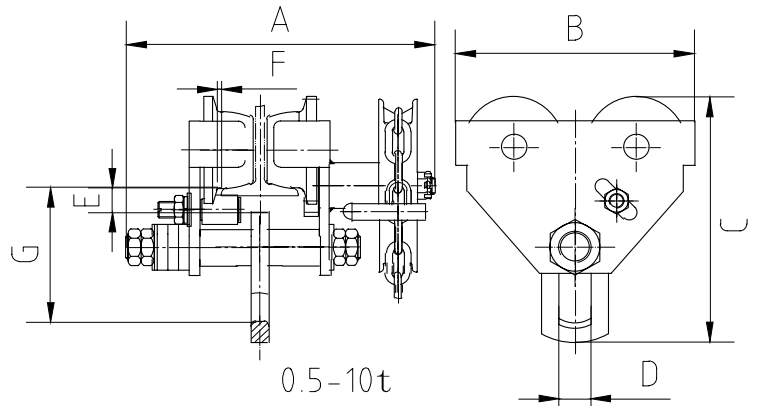

Technical information:

- Meets the WLL performance requirements of BS EN 13157.
- Black Color finish.
- Drop forged bolt type adjuster enables safe and speedy adjustment.
- Lightweight rugged construction.
- High grade steel sealed ball bearings for precise and smooth rolling.
- For use with hand and electric hoists.
- All trolleys are designed for use with same capacity HH Chain Blocks.
- Side plates are produced with trolley wheel guards for additional safety.
- Larger sizes available upon request.

TECHICAL DIMENSION	ProductCode	Capacity	BeamRange	A	B	C	D	Weight
		(Kgs)	(mm)	(mm)	(mm)	(mm)	(mm)	(Kgs)
	GCL0.5T	500	64-140	3085	212	198.5	24	11.6
	GCL1T	1000	76-165	3285	255	231.5	30.5	17
	GCL2T	2000	76-203	361.5	302	278	36	25.5
	GCL3T	3000	88-203	4285	344	338	45	39
	GCL5T	5000	125-203	434	378	393	60	57
	GCL10T	10000	136-203	4875	455	490	82	93
	GCL20T	20000	144-250	523	642	622	110	247.5